

The Ultimate Diving System
Northern Diver

www.ndiver.com

JUPITER & SATURN

REGULATOR MANUAL

JUPITER & SATURN OWNER'S MANUAL

COPYRIGHT NOTICE

This owner's manual is copyrighted, all rights reserved. It may not, in whole or in part, be copied, photocopied, reproduced, translated, or reduced to any electronic medium or machine readable form without prior consent in writing from Northern Diver (International) Ltd.

© 2003 Northern Diver (International) Ltd.

For the latest information about all Northern Diver products visit
www.ndiver.com



WARNING:

This manual provides essential instructions for the proper setup, inspection, use and care of your new regulator. Please take the time to read these instructions in order to understand and fully enjoy the features of your regulator.

Improper use of your regulator could result in serious injury or death.

CONTENTS



SAFETY	
PRECAUTIONS & WARNINGS	4
INTRODUCTION	5
FIRST STAGE	6
JUPITER ENVIRONMENTAL PROTECTION	6
SECOND STAGE	7
PREPARATION AND SET UP	7
MOUNTING THE FIRST STAGE ONTO THE CYLINDER VALVE	7
USING YOUR REGULATOR	8
PRIOR TO ANY DIVE	8
DIVING	9
DIVING IN COLD WATER	9
AFTER YOUR DIVE	10
CARE AND MAINTENANCE	10
DEALER SERVICE AND REPAIR	12
WARRANTY	12
SPARES KIT	13
TECHNICAL DIAGRAMS	14

JUPITER & SATURN

SAFETY

PRECAUTIONS & WARNINGS

Before using this regulator you must receive instruction and certification in SCUBA* diving from a recognized training agency. Use of SCUBA* equipment by uncertified or untrained persons is dangerous and can result in injury or death.

This regulator is not configured for commercial use with surface supplied air.

Always pressurize the regulator gradually by opening the cylinder valve SLOWLY.

NEVER apply any type of lubricant to any part of the regulator or cylinder valve.

DO NOT apply any type of aerosol spray to the regulator. Doing so may cause permanent damage to certain plastic components, including the second stage housing.

Factory prescribed service for this regulator must be performed at least once annually by a factory trained service technician who is employed by an authorized dealer. Disassembly, repair, or first stage adjustment must not be attempted by persons who are not factory trained and authorized by Northern Diver.

DO NOT leave a cylinder standing unsecured with the regulator attached to the valve. Doing so may cause permanent damage to the regulator and cylinder valve if the cylinder falls over.

DO NOT carry the regulator by the first stage when it is connected to a cylinder. Always carry the cylinder by the cylinder valve or an attached carrying device.

When diving in cold water (below 50°F, or 10°C), you must have received training and certification in the techniques of cold water diving from a recognized training agency.

This regulator is designed and intended for use only with clean, compressed atmospheric air (21% oxygen and 79% nitrogen), meeting the requirements of the EN 132 standard.

DO NOT use this equipment with any other gas or enriched oxygen mixture above 23% oxygen. Failure to observe this warning may result in serious injury or death due to fire or explosion.

NOTE: For information about regulators which are specifically designed and manufactured for use with oxygen enriched air consult your Northern Diver dealer.

* SCUBA = Self Contained Underwater Breathing Apparatus.

INTRODUCTION

Thank you for choosing a Northern Diver regulator.

This regulator has been designed and manufactured to meet or exceed all requirements for the EN250 standard and is CE approved for use.

Your Northern Diver regulator is supplied with a Limited Lifetime Warranty against defects in materials or workmanship. This warranty is not transferable beyond the original owner of the regulator. For more information, please read the warranty section of this manual and keep your receipt of purchase. The receipt of purchase is required whenever obtaining warranty service.

Your regulator's reliable function and performance depends on proper care and maintenance and should be regularly serviced by a suitably qualified person.

Prior to diving with your new Northern Diver regulator, you should read this manual in its entirety to become familiar with all aspects of set up, use and maintenance.

With proper care and maintenance your Northern Diver regulator should provide fun and safe diving for many years.

SATURN <input type="checkbox"/>		JUPITER <input type="checkbox"/>	
DATE OF PURCHASE		SUPPLIER	
SERIAL NUMBER			

WARNING: Improper use or misuse of any SCUBA* equipment may result in serious injury or death. It is important to read and understand this owner's manual completely before diving with your new regulator. However this manual is not a substitute for proper training and any diving should not be undertaken without proper training.

FIRST STAGE

There are two models in the Northern Diver regulator range; the *Saturn* is designed for normal diving and the *Jupiter* which has an environmentally sealed first stage and is intended for cold water and more extreme diving. Both regulators have a similar appearance and the user maintenance requirements for both is the same.

Both first stage units have two low pressure (LP) and one high pressure (HP) port on each side, giving a total of six ports.

The second stage hose and any octopus second stage hose should each be connected to one of the LP ports.

Drysuit inflation hoses and BCD inflation hoses can be connected to any of the LP ports.

The high pressure gauge hose should be connected to either of the HP ports.

The selection of which ports to use depends on how you prefer to configure your diving equipment, ie left hand or right hand routing of hoses, presence of accessories, etc.

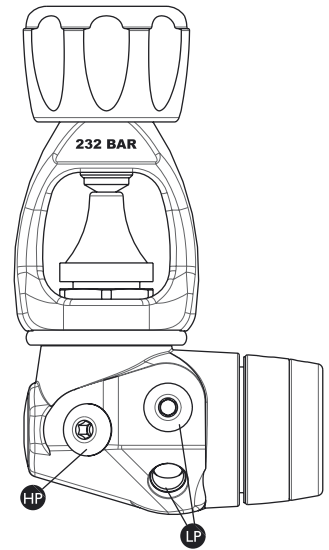

JUPITER ENVIRONMENTAL PROTECTION

For dirty water or cold water diving conditions, the Jupiter first stage employs an environmental sealing system. An end cap diaphragm seals the ambient chamber from the water, and an internal piston transfers ambient water pressure to the internal diaphragm. While helping to prevent ice formation inside the first stage, it should be noted that this environmental protection diaphragm will not prevent the second stage from freezing.

The Jupiter and Saturn regulators are sold with a standard yoke connection, and approved for use with cylinder pressures up to 232 bar. If you need to use your regulator with a high pressure cylinder equipped with a DIN valve, contact Northern Diver about the availability of a DIN connecting first stage.

WARNING: Do not attempt to modify the first stage to accept DIN fittings as this could lead to severe injury or death.

Northern Diver recommends that you take your regulator to an authorized dealer (www.ndiver.com/dealers) for the fitting of any items such as HP hoses, LP hoses, Octopus second stages, etc. Your dealer can also answer any questions you may have relevant to the information contained in this manual.

SECOND STAGE

The Jupiter and Saturn second stages allow the diver to adjust their sensitivity. By rotating the sensitivity adjustment control, the valve can work at maximum performance during a dive and can be set to reduced sensitivity for other times when the valve is not being used for breathing, such as surface swimming.

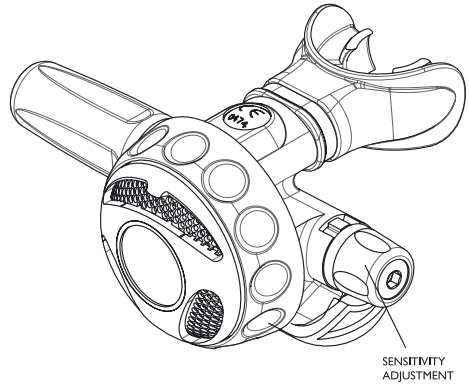

PREPARATION AND SET UP

Prior to connecting your regulator to an air cylinder, inspect the cylinder valve O-ring for any wear or damage. If the O-ring is damaged or worn it should be replaced before attaching the regulator.

MOUNTING THE FIRST STAGE ONTO THE CYLINDER VALVE

- 1 Slacken the yoke screw (A) of the first stage so that the dust cap (B) can be removed from the filter and air inlet.
- 2 Ensure the cylinder valve is facing away from you and turn the handle (C) anti-clockwise which will release a small amount of air from the cylinder. As soon as the hiss of released air is heard, close the valve. Any moisture or debris in the cylinder valve should be cleared by this action.
- 3 Place the first stage regulator over the cylinder valve so that the inlet fitting aligns with the O-ring of the cylinder valve. Hold the first stage in place and turn the yoke screw (A) clockwise. The yoke screw must locate into the small dimple (D) on the rear of the cylinder valve. Tighten the handle (A) finger-tight. Do not over-tighten.
- 4 Ensure that the high pressure gauge is facing away from you and then pressurize the regulator by slowly turning the cylinder valve screw (C) anti-clockwise. Open fully and then turn it back clockwise half a turn.

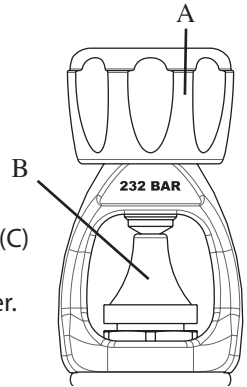
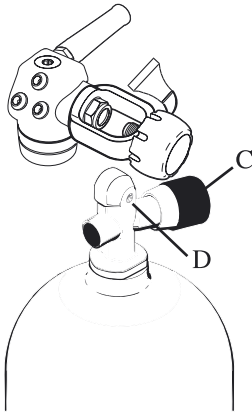

- 5 Listen for any leakage from the first stage. By immersing the first stage (whilst

attached to the cylinder and pressurized) in water, bubbles will indicate any leaks.

- 6 If air is seen leaking from between the first stage and cylinder valve, the O-ring may require replacing or re-seating in the cylinder valve. After replacement or reseating, test again for leaks as described previously. Should the test still indicate a leak, the system should be returned to an authorized dealer for further inspection.

USING YOUR REGULATOR

Prior to each dive, perform a comprehensive inspection of your regulator. DO NOT use a regulator that shows any indication of damage or incorrect performance. The regulator should be taken to an authorized dealer for inspection and service if you have any concerns

PRIOR TO ANY DIVE

- 1 Carefully inspect all hoses and ensure they are securely connected into the correct ports in the first stage. Also inspect all hoses, looking for any blistering, cuts and other damage. Any hose protectors should be pulled back to allow a proper inspection of the hose fittings, and inspect the hose condition underneath the protector.
- 2 Inspect the regulator first and second stage for any signs of damage.
- 3 Inspect the condition of the first stage filter by removing the dust cap. The filter should be clean and show no signs of corrosion or discoloration. Any discoloration on the filter may indicate that moisture has entered the first stage. Should this be the case, it is possible that corrosion may be forming inside. Internal corrosion can seriously impair the functioning of the regulator. Discolouration may also be present if the regulator has been used with a cylinder which has internal corrosion. Should this be the case, take the regulator and cylinder to your dealer for inspection.

CAUTION: If any discoloration is found on the filter, it is essential to take the regulator to your authorized dealer as soon as possible. Any delay may result in further corrosion of internal components.

- 4 For Jupiter only: Inspect the external sealing diaphragm for any signs of damage, deterioration or leakage. Also ensure the the external diaphragm retainer is tightly secured.

WARNING: If there is any indication of damage, deterioration or leakage to

the external diaphragm, DO NOT use the regulator until it has been inspected and serviced by an authorized dealer. Failure to have the regulator inspected and serviced may result in the regulator not functioning correctly or internally freezing.

- 5 Attach the first stage to a fully charged cylinder and gently open the cylinder valve (C). This will pressurize the regulator. Open the cylinder valve fully and then turn it back clockwise half a turn.
- 6 Press the purge button (on the front of the second stage) for a short duration to clear any dust and dirt which may have entered the second stage. After releasing the purge button listen to ensure that the air flow from the second stage has stopped.
- 7 Gently take several deep breaths from the regulator. It must be possible to breathe easily without resistance.
- 8 Ensure that the pressure gauge accurately shows the measurement of the air pressure inside the cylinder.

DIVING

When you are about to dive, place the second stage in your mouth and ensure that the regulator allows breathing at a comfortable rate. Ensure the sensitivity lever is set to allow maximum air flow.

WARNING: Any deep diving requires special training and equipment. You risk decompression sickness and other serious diving injuries if you attempt to dive beyond prescribed no-decompression limits without first obtaining sanctioned technical dive training. Beware - you risk serious injury and death.

DIVING IN COLD WATER

Before attempting any diving in cold water conditions, it is important for you and any divers with you to obtain certified training for cold water diving techniques. Use only equipment which has been specifically designed and maintained for cold water diving. Without these precautions, a freeze-up is possible. It is possible for icing or freeze-up to occur with a regulator that has been specially designed for cold water use. It is therefore essential to practice required cold water diving procedures and take special precautions.

DO NOT UNDERTAKE ANY COLD WATER DIVING WITHOUT PROPER CERTIFIED TRAINING.

AFTER YOUR DIVE

NOTE: To help prevent any contaminants from entering the regulator when it is removed from the cylinder, rinse your regulator completely in fresh water (if available) before depressurizing it and thoroughly dry the first stage and cylinder valve.

Removal of the Regulator from the Cylinder Valve

- 1 Close the cylinder air supply by turning the cylinder valve (C) fully clockwise. Do not over-tighten when closed.
- 2 Watch the pressure gauge and depress the second stage purge button. When the gauge reads zero and no airflow can be heard from the second stage, release the purge button.
- 3 Turn the yoke screw (A) counter-clockwise to loosen and remove the first stage from the cylinder valve.
- 4 Dry the dust cap (B) with a clean towel, or with low pressure air.
- 5 Place the dust cap (B) over the first stage inlet and seal it in place by tightening down the yoke screw (A).
- 6 When your regulator is dry and clean, store in the supplied Aluminium hard case.

CARE & MAINTENANCE

It is essential to provide proper preventative maintenance to ensure the best performance and maximum life of your Northern Diver Regulator. The following procedures should be performed routinely after each use to ensure that the regulator is ready for the next use (or for storage).

- 1 When the regulator is removed from the cylinder valve, wipe or blow the dust cap (B) dry, and then fix it securely over the first stage inlet. This is critical to prevent the ingress of moisture into the first stage.
- 2 As soon as possible after diving, the regulator should be thoroughly rinsed in fresh water while it is attached to a cylinder and still pressurized with air.
- 3 To thoroughly clean your regulator, soak it in warm (not exceeding 120°F) tap water for at least one hour. Preferably keep the regulator attached to a diving cylinder, open the cylinder valve to pressurize the regulator, and thoroughly soak both the first and second stages. Pressurizing the regulator will prevent moisture getting into the regulator while it soaks.

If it is not possible to soak the regulator while attached to a cylinder, it may be soaked unpressurized but ensure that the dust cap (B) is securely sealed over the inlet, and the second stage purge button is not depressed while the regulator is submerged or wet.

CAUTION: DO NOT loosen the first stage yoke screw or depress the second stage purge button if the regulator is submerged whilst not pressurized. Doing so will allow moisture inside the regulator and the regulator will require servicing at an authorized service centre before it should be used again for diving.

- 4 After soaking rinse the regulator thoroughly by flushing the first stage ambient chamber (Saturn, non-environmentally sealed model only), the second stage mouthpiece, and the openings in the second stage front cover with a pressurized stream of water. This will remove any deposits loosened during soaking. If the regulator is not pressurized, do not press the purge button during flushing or submersion. Doing so will allow moisture inside the regulator and the regulator will require servicing at an authorized service centre before it should be used again for diving.
- 5 Dry the regulator and hang by the first stage ensuring all remaining moisture drains from the second stages.
- 6 Do not store the regulator where it may be exposed to extreme heat or an electric motor which produces ozone. Prolonged exposure to extreme heat, ozone, chlorine and ultraviolet rays can cause premature degradation of parts and components.
- 7 Never store the regulator connected to the cylinder valve.
- 8 Do not use any type of solvent or petroleum based substances to clean or lubricate any part of the regulator. Do not expose any part of the regulator to aerosol spray which degrade rubber and plastic materials.

DEALER SERVICE & REPAIR

- 1 Do not assume that a regulator is in good working order if it has received little use since it was last serviced. Prolonged or improper storage means there is the possibility of internal corrosion and/or deterioration of O-ring seals.
- 2 Your regulator should be serviced at least yearly by an authorized dealer no matter how little use it may have had in that time. More frequent service may be necessary depending on the frequency of use and the environment in which it is used.
- 3 If the regulator is used for hiring or training, it will require overhaul and service every three to six months. Chlorinated swimming pool water is an especially damaging environment for all diving equipment.
- 4 DO NOT attempt to disassemble or service your regulator. Doing so may cause the regulator to malfunction, and will render the warranty null and void. All Northern Diver regulator servicing must be performed by an authorized dealer.

SERVICE YOUR REGULATOR AT LEAST ONCE A YEAR USING AN AUTHORIZED DEALER. YOUR PERSONAL SAFETY MAY DEPEND ON IT.

WARRANTY

Limited Lifetime Warranty

Northern Diver warrants to the original purchaser that the product will remain free from defects in material and workmanship throughout its useful life provided that it receives normal use, proper care and prescribed dealer service subject to those restrictions stated below.

This warranty does not apply to regulators subjected to misuse, abuse, neglect, modification or unauthorized service. This limited warranty is extended only to the original purchaser for products purchased directly from an authorized dealer and is not transferable. This warranty is limited to repair or replacement only at the discretion of Northern Diver.

WARNING: It is dangerous for untrained and uncertified persons to use the equipment covered by this warranty. Therefore, use of this equipment by an untrained person renders any and all warranties null and void. Use of SCUBA* equipment by anyone who is not a trained or certified diver, or receiving training under the supervision of an instructor, could lead to serious injury or death.

This warranty gives you specific legal rights. You may have rights which vary from country to country.

NORTHERN DIVER DISCLAIMS AND EXCLUDES ANY LIABILITY FOR INCIDENTAL OR CONSEQUENTIAL DAMAGES. SOME STATES IN THE U.S. AND CERTAIN FOREIGN COUNTRIES DO NOT ALLOW EXCLUSIONS OR LIMITATIONS OF LIABILITY FOR INCIDENTAL OR CONSEQUENTIAL DAMAGES, SO THIS MAY NOT APPLY TO YOU.

Restrictions

The following restrictions apply to this warranty:

- 1 This warranty does not cover normal wear of a regulator. Factory prescribed service by an authorized dealer is required at least once annually.
- 2 This warranty does not extend to damages caused by improper use, improper maintenance, neglect, unauthorized repairs, modifications, accidents, fire or casualty.
- 3 Cosmetic damage such as scratches, dents, and nicks are not covered by this warranty.
- 4 This warranty does not extend to equipment used for rental, commercial or military purposes.
- 5 This warranty covers products purchased in the UK. For warranties that may apply elsewhere, please contact your local dealer or distributor.

All warranty enquiries must be accompanied by proof of original purchase from an authorized dealer. Please save your sales receipt and present it whenever returning your regulator for warranty service.

SPARES KIT

The spares kit supplied with your Northern Diver regulator is intended for use by service technicians. They are not intended for use by unqualified personnel.

WARNING: Do not attempt to use the spares kit or dismantle or repair the regulator if you are not a certified technician for Northern Diver regulators. Doing so may cause the regulator to malfunction and result in serious injury or death. This will also render the warranty null and void. All Northern Diver regulator servicing must be performed by an authorized dealer.

TECHNICAL DIAGRAMS
SECOND STAGE

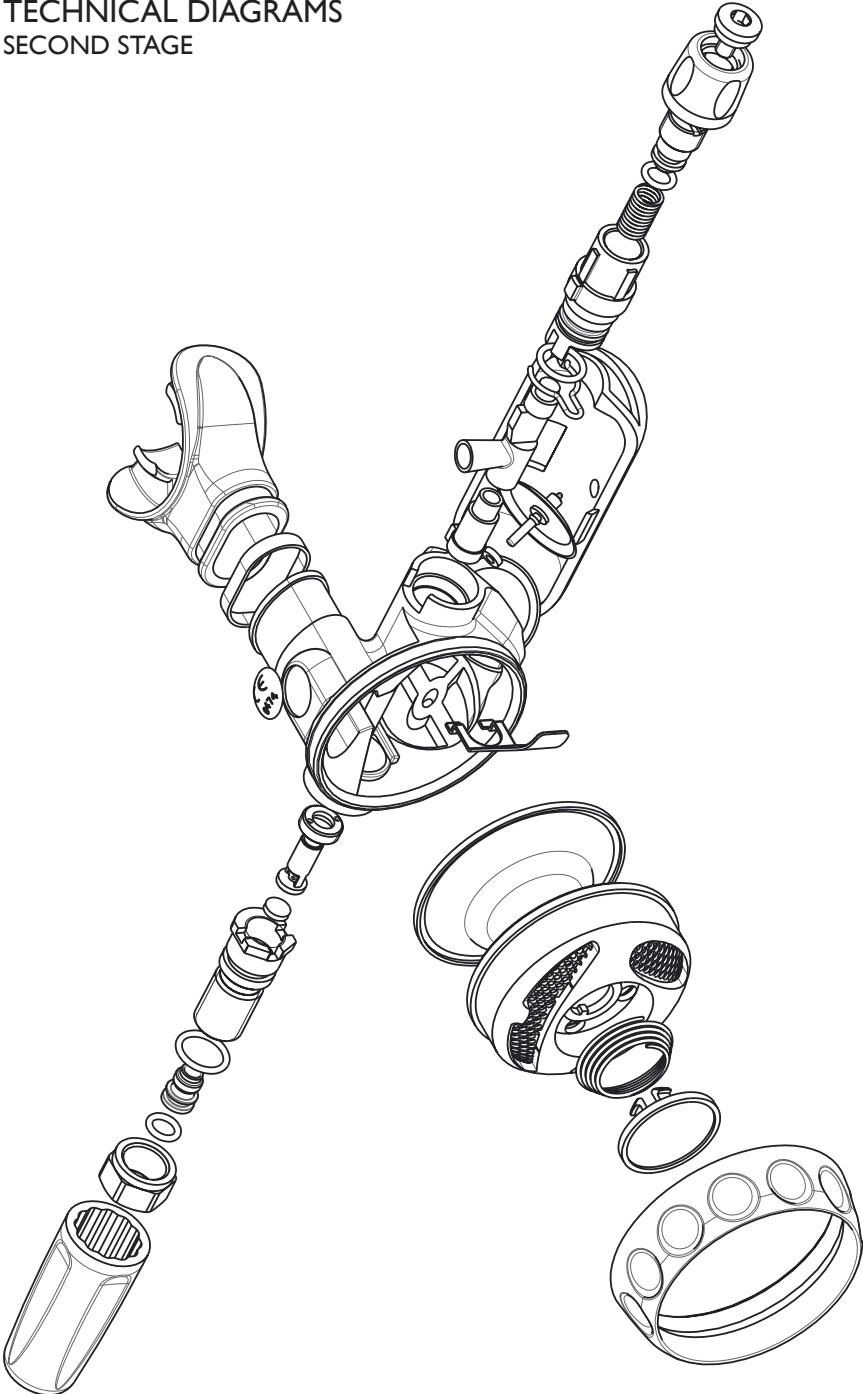

TECHNICAL DIAGRAMS
FIRST STAGE

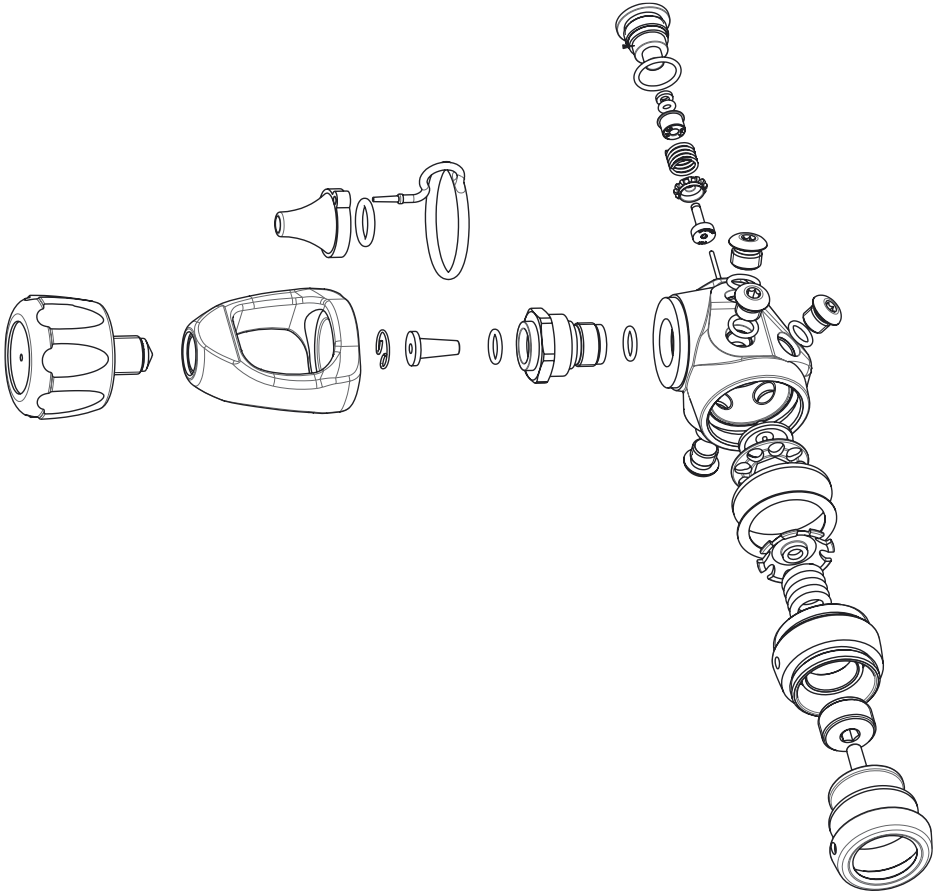

JUPITER & SATURN



NORTHERN DIVER (INTERNATIONAL) LTD.
www.ndiver.com